



POLTRONE SPECIALISTICHE

SPECIALISTIC CHAIRS

FAUTEUILS PROFESSIONNELS

**I** Euroclinic è un'Azienda di Produzione nel settore delle attrezzature elettro-medicali che, nel corso degli ultimi anni, con spiccato dinamismo, ha intensificato l'area Sviluppo & Ricerca investendo su nuovi progetti di alta tecnologia abbinata ad uno stile italiano ricercato, innovativo e di forte personalità. Il suo team affiatato di ingegneri, designers e managers professionisti è costantemente impegnato nello sviluppo di progetti su misura ("chiavi in mano") al fine di soddisfare al meglio le esigenze del cliente, mantenendo competitivo il rapporto qualità-prezzo. Euroclinic è lieta oggi di proporre la sua linea di Poltrone Specialistiche (Ginecologia/Urologia, Prelievo, Multispecialistiche) con immagini chiare e didascalie descrittive che seguiranno in questo catalogo e che Vi consentiranno di approfondire aspetti tecnici o puramente estetici.

**GB** Euroclinic as a leading manufacturer Company of electro-medical equipments thanks to its propulsive dynamism during the last years has intensified its Research & Development activity by investing on several new projects of high-technology combined to a refined, innovative and strictly italian style. Euroclinic's team of engineers, designers and managers, continuously research and develop "turn-key" custom-made projects aiming at higher customer satisfaction at the most competitive price. Euroclinic is glad to propose in the next pages of this catalogue the Specialistic Chairs line (Gynaecology/Urology, blood-taking and multi-specialistic chairs) with clear pictures and relative descriptions, that will allow you to go to deep into all technical and aesthetical features.

**F** Euroclinic est une Entreprise de production du secteur des équipements électro-médicaux qui, au cours des dernières années, avec remarquable dynamisme, a intensifié l'activité de son département Recherche & Développement, en investant sur plusieurs nouveaux projets de haute technologie combinée à un style italien recherché, d'innovation et de forte personnalité. Son équipe d'ingénieurs et designers professionnels est engagé sans interruption dans nouveaux projets ("projets à mesure") en cherchant à satisfaire au mieux les exigences des clients, en gardant toutefois le compétitif rapport qualité-prix. Euroclinic a le plaisir de vous proposer dans les pages suivantes sa ligne de Fauteuils Professionnels (Gynécologie/Urologie, prélèvement, multi-professionnels), avec images claires et relatives descriptions, que Vous permettront de creuser des aspects techniques ou purement esthétiques.

## Urologia - Urology - Urologie

SUPREMA U-500 ..... → 2.....

## Ginecologia - Gynaecology - Gynecologie

SUPREMA G-200 ..... → 6.....

GYNEX PROFESSIONAL ..... → 12.....

GYNEX ..... → 16.....

## Multi-specialistica - Prelievo Multi-specialistic - Blood taking Multi-professionnel - Prélèvement

MEDICONCEPT ..... → 22.....

OTO P/E ..... → 26.....

SEGGIOLINI - Stools - Tabourets ..... → 30.....

PROGETTAZIONE ..... → 32.....  
Design department - Departement projects

COLORI - Colours - Couleurs ..... → 33.....

DATI TECNICI ..... → 35.....  
Technical features  
Fiches techniques



# SUPREMA U-500

**I** Poltrona professionale progettata per l'attività ambulatoriale urologica in reparti o centri specializzati che esigono attrezzature medicali di affidabile funzionalità e di alto comfort sia per l'operatore che per il paziente. **SUPREMA U-500**, nella gamma delle poltrone specialistiche a marchio Euroclinic, risponde a tali requisiti grazie ad avanzate tecniche produttive applicate a nuovi principi di meccanica ed elettronica per ottenere la massima modularità e grazie al gusto estetico espresso nelle linee semplici ottimizzando l'ergonomia. **SUPREMA U-500** è caratterizzata da:

- Solida struttura in metallo verniciato a polveri epossidiche rifinita con eleganti carter termoformati in ABS ad alta resistenza
- 3 Motori di alta qualità e potenza fino a 8000N per la movimentazione indipendente di salita/discesa, schienale e seduta.
- Inclinazione della poltrona oltre i 20° nella posizione di Trendelenburg. Garantita massima stabilità e affidabilità
- Rotazione di 90° a dx e 90° a sx
- Controllo della poltrona nei suoi movimenti indipendenti tramite pedale wireless che è anche provvisto di 4 memorie: 3 per il richiamo di posizioni a scelta dell'operatore e 1 per il richiamo della posizione "zero" in cui la poltrona è a riposo. Sistema di settaggio memorie automatico con segnale acustico di fine operazione
- Gambalone singolo: elemento tappezzato e amovibile da applicarsi per raggiungere la posizione fissa a lettino
- Asta-flebo telescopica fissata al basamento su supporto orientabile di 90°

Le parti tappezzate della poltrona sono in gommapiuma indeformabile ad alta densità con rivestimento in skay bielastico, resistente alle lacerazioni, antibatterico e di facile pulizia. **SUPREMA U-500** è provvista di tutti gli accessori in uso per una completa attività urologica.

**GB** Professional chair designed specifically for the urology examination in specialized department or clinics that require medical equipments with highly reliable performance and maximum comfort for both operator and patient. Among the assorted Euroclinic range of specialistic chairs, **SUPREMA U-500** satisfies such requirements thanks to advanced production techniques applied to new principles in mechanics and electronics to gain best modular solutions and to the taste for simple esthetical lines and ergonomics. **SUPREMA U-500** is equipped with:

- Solid construction in metal painted with epoxy powders refined with elegant covers molded in ABS at high resistance
- 3 Powerful motors of high quality (up to 8000N) operating electrically and separately the up/down, back rest and seat movements.
- 20° Inclination when in Trendelenburg position; maximum stability and efficiency are granted
- 90° rotation angle on the right and 90° on the left
- Wireless pedal control of each independent chair's movement. It is also provided with 4 memories: 3 positions chosen by the operator to be recalled and 1 to recall the resting position of the chair ("zero" position). Automatic memory setting system with acoustic alarm when operation terminated.
- Single-section leg rest: removable upholstered part that can be set on the chair to reach the fixed bed position
- Extensible holder rod for phlebo-bottle fixed at the chair's basement on a 90° revolving support

The upholstered parts of the chair are composed of high-density and non-deformable foam pelted with bi-elastic, tear resistant, antimicrobial skai, very easy to clean. **SUPREMA U-500** is fully equipped with all necessary accessories for a professional urology practice.

**F** Fauteuil professionnel pour l'activité d'examen urologique dans les salles des hôpitaux ou dans centres spécialisés, qui nécessitent équipements médicaux de fiable fonctionnalité et d'haut confort soit pour l'opérateur soit pour le patient. Dans la gamme des fauteuils professionnels Euroclinic, **SUPREMA U-500** répond à ces requis grâce aux techniques productives avancées appliquées aux nouvelles notions introduites par la mécanique et l'électronique, au fin d'obtenir la maximum modularité et aussi grâce au goût esthétique exprimé dans les lignes simples avec l'optimisation de l'ergonomie.

**SUPREMA U-500** est caractérisé par :

- Solide structure en métal peint époxy avec couvertures très élégantes thermoformées en ABS avec haute résistance
- 3 moteurs d'haute qualité et puissance jusqu'à 8000N pour le mouvement indépendant d'élévation/descente, du dossier/assise.
- Inclinación du fauteuil plus de 20° dans la position TRENDELENBURG. On garantit maximum stabilité et fiabilité.
- 90° angle de rotation à droite et 90° à gauche
- Contrôle du fauteuil dans ses mouvements indépendants à travers pédale WIRELESS, qui est pourvu de 4 mémoires aussi : trois pour le rappel des positions à choix de l'opérateur et une pour le rappel de la position « zéro », dans laquelle le fauteuil se trouve à repos. Système d'ajustement mémoires automatique avec signal acoustique d'opération conclue.
- Jambière single : élément tapissé et amovible, à appliquer au fin d'obtenir la position fixe du lit
- Porte-sérum réglable en hauteur fixée à la base sur un support orientable de 90°

Les parties tapissées du fauteuil sont en mousse indéformable à haute densité avec revêtement en skay bielastique, résistant aux déchirures, antibactérique et de nettoyage très simple. Paire d'accoudoirs en métal (amovibles) dessinés pour garantir une prise plus sûre pour le patient (ils servent comme poignées aussi). **SUPREMA U-500** est complètement équipé avec tous les accessoires pour une bonne activité professionnelle de urologie.

# SUPREMA U-500



# SUPREMA U-500



- I** PEDALE WIRELESS MULTIFUNZIONE
- GB** MULTIFUNCTION WIRELESS PEDAL
- F** PEDAL MULTI-FONCTION SAN FIL



- I** REGGICOSCE ANATOMICI & SNODATI
- GB** ANATOMICAL & MULTI-ADJUSTABLE LEG-REST
- F** APPUI-JAMBES ANATOMIQUE & DESARTICULE



- I** PORTA-ROTOLO (sullo schienale)
- GB** PAPER-ROLL SUPPORT (on the back-rest)
- F** PORTE ROULEAU POUR DRAP (Position côté dossier)



# SUPREMA U-500



- I** Cuscino centrale da posizionarsi tra seduta e gambalone per uso lettino
- GB** Central cushion for filling the empty space between seat and single-leg rest at bed position
- F** Coussin central à placer entre l'assise et la jambière dans la position de lit

- I** 4 Guide laterali in acciaio su i due lati dello schienale e della seduta
- GB** 4 Stainless steel rails set on both sides of seat and back rest
- F** 4 Guides latérales en acier fixées aux 2 côtés du dossier et de l'assise

- I** VASCA IN ACCIAIO estraibile con sistema di drenaggio liquidi tramite tubo corrugato
- GB** SECRETION BASIN IN STAINLESS STEEL provided with drainage system for waste liquids by a coiled tube
- F** CUVETTE MÉTALLIQUE extraible complète de système de drainage liquides à travers un tuyau corrugué



# SUPREMA G-200

**I** Poltrona professionale progettata per l'attività ambulatoriale ginecologica in reparti o centri specializzati che esigono attrezzature medicali di affidabile funzionalità e di alto comfort sia per l'operatore che per il paziente. **SUPREMA G-200**, nella gamma delle poltrone specialistiche a marchio Euroclinic, risponde a tali requisiti grazie ad avanzate tecniche produttive applicate a nuovi principi di meccanica ed elettronica per ottenere la massima modularità e grazie al gusto estetico espresso nelle linee semplici ottimizzando l'ergonomia. **SUPREMA G-200** è caratterizzata da:

- Solida struttura in metallo verniciato a polveri epossidiche rifinita con eleganti carter termoformati in ABS ad alta resistenza
- 4 Motori di alta qualità e potenza fino a 8000N per la movimentazione indipendente di salita/discesa, schienale, seduta e gambalone
- Inclinazione della poltrona oltre i 20° nella posizione di Trendelenburg. Garantita massima stabilità e affidabilità
- Rotazione di 90° a dx e 90° a sx
- Controllo della poltrona nei suoi movimenti indipendenti tramite pedale wireless che è anche provvisto di 4 memorie: 3 per il richiamo di posizioni a scelta dell'operatore e 1 per il richiamo della posizione "zero" in cui la poltrona è a riposo. Sistema di settaggio memorie automatico con segnale acustico di fine operazione
- Coppia di reggi-talloni, in acciaio anodizzato, regolabili in altezza e provvisti di poggipiè sagomato e imbottito
- Asta-flebo telescopica fissata al basamento su supporto orientabile di 90°

Le parti tappezzate della poltrona sono in gommapiuma indeformabile ad alta densità con rivestimento in skay bielastico, resistente alle lacerazioni, antibatterico e di facile pulizia. **SUPREMA G-200** è provvista di tutti gli accessori in uso per una completa attività ginecologica.

**GB** Professional chair designed specifically for the gynaecology examination in specialized department or clinics that require medical equipments with highly reliable performance and maximum comfort for both operator and patient. Among the assorted Euroclinic range of specialistic chairs, **SUPREMA G-200** satisfies such requirements thanks to advanced production techniques applied to new principles in mechanics and electronics to gain best modular solutions and to the taste for simple esthetical lines and ergonomics. **SUPREMA G-200** is equipped with:

- Solid construction in metal painted with epoxy powders refined with elegant covers molded in ABS at high resistance
- 4 Powerful motors of high quality (up to 8000N) operating electrically and separately the up/down, back rest, seat and legrest movements.
- 20° Inclination when in Trendelenburg position; maximum stability and efficiency are granted
- 90° rotation angle on the right and 90° on the left
- Wireless pedal control of each independent chair's movement. It is also provided with 4 memories: 3 positions chosen by the operator to be recalled and 1 to recall the resting position of the chair ("zero" position). Automatic memory setting system with acoustic alarm when operation terminated.
- Extensible holder rod for phlebo-bottle fixed at the chair's basement on a 90° revolving support
- Couple of footrest in stainless steel, height adjustable and provided with padded-shaped foot supports

The upholstered parts of the chair are composed of high-density and non-deformable foam pelted with bi-elastic, tear resistant, antimicrobial skai, very easy to clean. **SUPREMA G-200** is fully equipped with all necessary accessories for a professional gynaecology practice.

**F** Fauteuil professionnel pour l'activité d'examen gynécologique dans les salles des hôpitaux ou dans centres spécialisés, qui nécessitent équipements médicaux de fiable fonctionnalité et d'haut confort soit pour l'opérateur soit pour le patient. Dans la gamme des fauteuils professionnels Euroclinic, **SUPREMA G-200** répond à ces requis grâce aux techniques productives avancées appliquées aux nouvelles notions introduites par la mécanique et l'électronique, au fin d'obtenir la maximum modularité et aussi grâce au goût esthétique exprimé dans les lignes simples avec l'optimisation de l'ergonomie. **SUPREMA G-200** est caractérisé par :

- Solide structure en métal peint époxy avec couvertures très élégantes thermoformées en ABS avec haute résistance
- 4 moteurs d'haute qualité et puissance jusqu'à 8000N pour le mouvement indépendant d'élévation/descente, du dossier/assise et de l'appui-jambes.
- Inclinacion du fauteuil plus de 20° dans la position TRENDELENBURG. On garantit maximum stabilité et fiabilité.
- 90° angle de rotation à droite et 90° à gauche
- Contrôle du fauteuil dans ses mouvements indépendants à travers pédale WIRELESS, qui est pourvu de 4 mémoires aussi : trois pour le rappel des positions à choix de l'opérateur et une pour le rappel de la position « zéro », dans laquelle le fauteuil se trouve à repos. Système d'ajustement mémoires automatique avec signal acoustique d'opération conclue.
- Porte-sérum réglable en hauteur fixée à la base sur un support orientable de 90°
- Couple de appui-pieds en acier, réglable en hauteur et pourvus de base façonnée et rembourrée

Les parties tapissées du fauteuil sont en mousse indéformable à haute densité avec revêtement en skay bielastique, résistant aux déchirures, antibactérique et de nettoyage très simple. Paire d'accoudoirs en métal (amovibles) dessinés pour garantir une prise plus sûre pour le patient (ils servent comme poignées aussi). **SUPREMA G-200** est complètement équipé avec tous les accessoires pour une bonne activité professionnelle de gynécologie

# SUPREMA G-200



## SUPREMA G-200



- I PEDALE WIRELESS MULTIFUNZIONE
- GB MULTIFUNCTION WIRELESS PEDAL
- F PEDAL MULTI-FONCTION SAN FIL



- I REGGITALLONI SAGOMATI E IMBOTTITI
- GB PADDED-SHAPED FOOT-REST
- F APPUI-PIEDS FACONNES ET REMBOURRES

- I COLPOSCOPIO 150FC di Karl Zeiss montato su poltrona
- GB COLPOSCOPE 150FC of Karl Zeiss mounting on gynae-chair
- F COLPOSCOPE 150FC de Karl Zeiss monté sur fauteil gyno

# SUPREMA G-200



- I** GAMBALONE ELETTROMOVIMENTATO (fino a Trendelenburg)
- GB** ELECTRICALLY-OPERATED LEGREST (up to Trendelenburg)
- F** APPUI-JAMBES ELECTRIQUE (jusqu'à Trendelenburg)



- I** PORTA-ROTOLO (sullo schienale)
- GB** PAPER-ROLL SUPPORT (on the back-rest)
- F** PORTE ROULEAU POUR DRAP (Position côté dossier)

# SUPREMA G-200



- I** REGGICOSCE ANATOMICI & SNODATI
- GB** ANATOMICAL & MULTI-ADJUSTABLE LEG-REST
- F** APPUI-JAMBES ANATOMIQUE & DESARTICULE

## SUPREMA G-200



- I** 4 Guide laterali in acciaio su i due lati dello schienale e della seduta )
- GB** 4 Stainless steel rails set on both sides of seat and back rest
- F** 4 Guides latérales en acier fixées aux 2 côtés du dossier et de l'assise

# GYNEX PROFESSIONAL

- I** Nata da una base meccanica di sicura affidabilità, Gynex Professional è una poltrona che sintetizza funzionalità, estetica ed ergonomia. Gynex Professional è in grado di soddisfare tutte le necessità del paziente e dell'operatore proprie di una visita ginecologica professionale. Gynex Professional è provvista di versatili accessori: porta-rotolo carta posteriore, vaschetta in metallo, maniglie cromate, i reggi-cosce tappezzati. L'evoluzione tecnologica ha portato sul modello base all'introduzione di altri due motori e movimentazioni elettriche di schienale e gambale, che hanno reso la poltrona più moderna e professionale. Grazie al movimento combinato di schienale e seduta, con meccanismo di auto-bilanciamento, azionato tramite due silenziosi attuatori a bassa tensione (ciascuno di 1000 N), Gynex Professional è adattabile a qualunque tipo di corporatura, garantendo al paziente massimo comfort. I braccioli imbottiti e tappezzati proteggono il paziente in un piacevole relax e sono singolarmente orientabili ed asportabili. Lo schienale è provvisto di poggiatesta amovibile e regolabile in altezza. L'ampio e soffice gambale gode di regolazione autonoma ed indipendente da tutti gli altri movimenti, che avviene tramite due attuatori silenziosi a bassa tensione, ciascuno di 1000 N. La poltrona è movimentata da un silenzioso attuatore elettrico alimentato a bassa tensione, che consente un'escursione verticale di 40 cm, partendo dalla posizione di zero. I comandi elettrici vengono azionati da una pulsantiera comoda ed ergonomica. Gynex Professional, pensata come poltrona ginecologica, può essere facilmente trasformata in lettino da visita (posizione completamente orizzontale).
- GB** Gynex Professional chair (developed from a guaranteed reliability) can synthesize functionality, aesthetics, ergonomics. It can satisfy all patient and user needs linked to a professional gynaecologic visit. Gynex professional is provided with versatile accessories: back paper-roll dispenser, metal tub, chromed handles, upholstered leg-supports. Technologic evolution has introduced, in comparison with the standard base model, 2 more motors and electric movements of the back-rest and leg-rest, which make the chair more modern and professional. Thanks to the combined movement of backrest and seat by means of self-balancing system (operated by 2 silent low tension actuators of 1000 N each one), Gynex Professional is suitable for any physique, granting maximum comfort to the patient. The padded and pelted arm-rests allow a relaxing and protecting sitting position and they are singularly revolving and removable. The backrest is provided with removable and regulating head-rest in height. The wide and soft leg-rest has independent adjustment movement through 2 silent low tension actuators (1000 N each one). This chair is moved by a silent low tension actuator, which allows a vertical excursion of 40 cm, starting from zero position. The electrical motors are controlled by a comfortable and ergonomic hand-switch control. GYNEX Professional - through as a professional gynaecological chair - can be easily transformed in examination bed (completely horizontal position).
- F** Née d'une base mécanique de sure fiabilité, Gynex Professional est un fauteuil réunissant fonctionnalité, goût esthétique et ergonomie. Il a été conçu pour la maxime satisfaction du patient et de l'opérateur au siège d'une visite gynécologique et urologique professionnelle. Gynex professional a plusieurs nouveaux accessoires très versatiles: porte-papier postérieure, cuvette métallique, poignées chromées, repose-jambes rembourrés. L'évolution technologique, en comparaison avec le modèle standard de base, a permis l'introduction de 2 ultérieurs moteurs et le mouvement électrique du dossier et jambièrè qui ont rendu le fauteuil plus professionnel et moderne. Grâce au mouvement synchronique du dossier et de l'assise avec mechanisme d'auto balancement aidé par 2 silencieux actuateurs à baisse tension (1000 N chacun), Gynex Professional peut s'adapter à n'importe quelle taille, en garantissant au patient le maximum du confort. Les repose-bras rembourrés et tapissés protègent le patient en position de relax et ils sont singulièrement amovibles et orientables. Le dossier est pourvu d'appuie-tête amovible et réglable en hauteur. L'ample et moelleux repose-jambes possède réglage autonome et indépendant de tout autre mouvement du fauteuil à travers 2 actuateurs à baisse tension (1000 N chacun). Gynex Professional est mouvementé par un silencieux vérin électrique, alimenté à baisse tension qui permet une excursion verticale de 40 cm, en partant de la position de zéro. Les commandes électriques sont activés par une un command manuel à interrupteurs. Gynex Professional, pensé comme fauteuil de gynécologie, peut facilement être transformé en lit de visite (position complètement horizontale).

# GYNEX PROFESSIONAL



# GYNEX PROFESSIONAL



**I** *Nuovo SISTEMA BLOCCAGGIO  
REGGICOSCE*

**GB** *New ADJUSTABLE LEG-REST  
LOCKING DEVICE*

**F** *Nouveau SYSTÈME RÉGLABLE DE  
BLOCAGE POUR RÉPOSE-JAMBE*

# GYNEX PROFESSIONAL



**I** *Controllo manuale con Tastiera  
Movimentazione elettrica di schienale, seduta e gambalone*

**GB** *Chair control by hand key-board  
Back-rest, seat and leg-rest electrically operated*

**F** *Contrôle manuel par clavier  
Mouvementation électrique du dossier, de la siége et de  
l'appui-jambes*

# GYNEX

**I** Gynex è una poltrona professionale di base che nelle due versioni a 1 o 2 motori, soddisfa paziente ed operatore in tutte le necessità proprie di una visita ginecologica e urologica professionale. Oltre alla coppia di reggicoste in poliuretano e reggitaloni telescopici, GYNEX è provvista di nuovi versatili accessori: porta-rotolo carta posteriore, vaschetta in metallo, maniglie cromate.

Grazie al movimento combinato di schienale e seduta, con meccanismo di auto-bilanciamento servoassistito da molla a gas, è adattabile a qualsiasi tipo di corporatura, garantendo al paziente massimo comfort. I braccioli imbottiti e tappezzati proteggono il paziente in un piacevole relax, e sono singolarmente orientabili ed asportabili. Lo schienale è provvisto di poggiatesta amovibile e regolabile in altezza. L'ampio e soffice gambale gode di regolazione autonoma ed indipendente da tutti gli altri movimenti, con meccanismo di blocco meccanico automatico.

La poltrona è movimentata da un silenzioso attuatore elettrico alimentato a bassa tensione, che consente un'escursione verticale di 40 cm – partendo dalla posizione zero. I comandi elettrici vengono azionati da una pedaliera bipartita collegata da apposito cavo.

GYNEX – pensata come poltrona ginecologica – può essere facilmente trasformata in lettino da visita (posizione completamente orizzontale).

**GB** GYNEX, in its version with 1 or 2 motors, is a basic chair for professional gynaecological and urological examination granting high satisfaction to both patient and operator, in view of a professional gynaecological and urological examination. In addition to polyurethane leg-supports and extensible foot-rests now you find brand new accessories: rear paper-roll dispenser, metal basin and chromed handles.

Thanks to the combined movement of back-rest and seat by means of self-balancing system operated by gas spring, GYNEX chair is suitable for any physique granting maximum comfort to the patient. The padded and pelted arm-rests allow a relaxing and protecting sitting position, and are singularly revolving and removable. The back-rest is provided with removable and regulating head-rest in height. The wide and soft leg-rest has independent adjustment movement with autonomous locking device.

The chair is operated by a silent electrical actuator, with low tension power supply, enhancing a vertical excursion of 40 cm – starting from "zero" position. The electrical drives are controlled by a "double" foot-control, connected to the chair by a cable.

GYNEX – thought as a professional gynaecological chair – can be easily transformed in examination bed (completely horizontal position).

**F** GYNEX est un fauteuil professionnel que dans sa version avec 1 ou 2 moteurs garantie la plus haute satisfaction du patient et de l'opérateur au siège d'une visite gynécologique et urologique professionnelle. Outre au pair de repose-jambes en polyuréthane gris aux repose-pieds télescopiques, GYNEX a plusieurs nouveaux accessoires - très versatiles: porte-papier postérieur, cuvette métallique, poignées chromées.

Grâce au mouvement synchronique du dossier et de l'assise, avec mécanisme d'auto balancement aidé par ressort à gaz, GYNEX peut s'adapter à n'importe quelle taille, en garantissant au patient le maximum du confort. Les repose-bras, rembourrés et tapissés, protègent le patient en position de relax et sont singulièrement amovibles et orientables. Le dossier est pourvu d'appui-tête amovible et réglable en hauteur. L'ample et moelleux repose-jambes en skay possède réglage autonome et indépendant de tout autre mouvement du fauteuil, avec mécanisme de blocage automatique.

Le fauteuil est mouvementé par un silencieux vérin électrique, alimenté à basse tension, qui permet une excursion verticale de 40 cm – en partant de la position zéro. Les commandes électriques sont activées par une pédale double, avec câble exprès.

GYNEX – pensé comme fauteuil de gynécologie – peut facilement être transformé en lit de visite (position complètement horizontale).

# GYNEX



# GYNEX



- I** *Vaschetta in plastica capacità 3 lt in dotazione (disponibile in acciaio-accessorio su richiesta)*
- GB** *Plastic basin with 3 lt. capacity as standard application (at request available in stainless- steel)*
- F** *Bassin en plastique avec capacité 3 lt. application standard (disponible en inox sur demande)*



# GYNEX



**I** MOVIMENTO SINCRONIZZATO DI SEDUTA E SCHIENALE, CON SISTEMA DI AUTOBILANCIAMENTO SERVO-ASSISTITO DA MOLLA A GAS.  
Altezza minima seduta: cm. 57 – Altezza massima seduta: cm. 96

**GB** SYNCHRONIZED MOVEMENT OF SEAT AND BACKREST, WITH SELF-BALANCING SYSTEM AIDED BY GAS SPRING.  
Seat minimum height: cm. 57 – Seat maximum height: cm. 96

**F** MOUVEMENT SYNCHRONISE D'ASSISE ET DOSSIER, AVEC SYSTEME D'AUTO BALANCEMENT AIDE PAR RESSORT A GAZ.  
Minimum hauteur de l'assise: cm. 57 – Maximum hauteur de l'assise: cm 96

## ACCESSORI PER GYNEX PROFESSIONAL & GYNEX

ACCESSORIES FOR GYNEX PROFESSIONAL & GYNEX  
 ACCESSOIRES POUR GYNEX PROFESSIONAL & GYNEX

- I MANIGLIE CROMATE
- GB CHROMED HANDLES
- F POIGNEES CHROMEES



- I PORTA-ROTOLO (sullo schienale)
- GB PAPER-ROLL SUPPORT  
(on the back-rest)
- F PORTE ROULEAU POUR DRAP  
(Position côté dossier)



- I VASCHETTA METALLO
- GB METAL BASIN
- F CUVETTE METALLIQUE



- I REGGITALLONI ESTENSIBILI (in acciaio cromato)
- GB EXTENSIBLE FOOT-REST (in chromed steel)
- F REPOSE-PIEDS EXTENSIBLES (en acier chromé)





# MEDICONCEPT

POLTRONA MULTISPECIALISTICA

MULTI-SPECIALISTIC CHAIR

FAUTEUIL MULTIPROFESSIONNEL

- I** *MEDICONCEPT è una poltrona specialistica che garantisce al paziente ottima stabilità, grazie alla solida struttura ed alla grande ergonomia d'insieme. Presenta un movimento combinato dello schienale e della seduta (con angolo costante), rivestiti in morbido Peltex. E' possibile raggiungere la posizione di Trendelemburg e la posizione a lettino (presenta un comodo cuscino lombare). Mediconcept, che comprende un poggiatesta anatomico amovibile regolabile in altezza, è dotata di 3 motori da 6000 N che consentono la movimentazione indipendente di salita e discesa, della seduta e dello schienale. La poltrona, in grado di raggiungere una rotazione di 85° a dx e a sx con sistema di bloccaggio, si presenta in una solida struttura e basamento in metallo verniciato a polveri epossidiche. E' importante notare i braccioli imbottiti ed indipendenti, sincronizzati al movimento dello schienale. E' innovativo il gambale unico imbottito, studiato per garantire massimo comfort al paziente. Il pedale multifunzione, oltre a movimentare la poltrona, permette la memorizzazione di 3 posizioni di lavoro da parte dell'operatore; in più, si ha la possibilità di richiamare la memoria fissa di uscita del paziente, già preimpostata. Con il bracciolo e l'asta portaflebo diventa una poltrona professionale ad uso prelievo.*
- GB** *It is a specialist chair that gives to the patient a great steadiness thanks to its solid construction. It has a combined movement of backrest and seat (covered in smooth Peltex) with constant angle. It is possible to get Trendelemburg position and bed position (lomber pillow). Mediconcept, provided with an anatomical head-rest that is removable and high-regulating, has 3 motors of 6000 N – allowing independent movement of seat and backrest. The chair, able to get a rotation of 85° to the right and left with locking system, is characterized by a steady structure and basement painted in epossidic powders. Please, note the padded and independent armrests, synchronized to the backrest movement. The padded single leg-rest is innovative, conceived to guarantee maximum comfort to the patient. The multifunction foot-control, besides operating the chair, also allows the operator to memorize 3 working positions; moreover, it is possible to recall the fixed memory for patient exit. If equipped with extensible holder rod for phlebo-bottle and articulated armrest it becomes a professional blood-taking chair.*
- F** *C'est un fauteuil pour spécialiste qui offre au patient une stabilité exceptionnelle grâce à sa solide structure. Il offre un mouvement combiné de dossier et assise avec angle constant, couverts en pratique Peltex. C'est possible obtenir la position de Trendelemburg et la position à lit étendu (coussin lombaire). Mediconcept, qui inclut un repose-tête anatomique et réglable en hauteur, est doué de Trois moteurs de 6000 N qui consentent le mouvement indépendant de montée et descente, de l'assise et du dossier. Le fauteuil, qui peut gagner une rotation de 85° à droite et à gauche avec système de blocage de la rotation, se présente avec une solide structure et base en métal vernissé aux poudres époxydiques. C'est important remarquer les repose-bras rembourrés et indépendants synchronisés au mouvement du dossier. C'est Innovateur le repose-jambes pièce unique rembourré, étudié exprès pour garantir au patient maximum comfort. La Pédale multifonction, qui règle le mouvement du fauteuil, permet à l'opérateur la mémorisation de 3 positions de travail; de plus, c'est possible rappeler la mémoire fixe de sortie du patient. Pourvu de porte-sérum réglable en hauteur et appui-bras il devient un fauteuil professionnel pour prélèvement.*

# MEDICONCEPT



# MEDICONCEPT



I PEDALE WIRE-LESS

I PEDALE CON CAVO

GB WIRE-LESS OPERATING FOOT CONTROL

GB FOOT CONTROL WITH CABLE

F PÉDALE SANS FIL

F PÉDALE AVEC FIL

# MEDICONCEPT



**I** *Asta portaflebo e bracciolo prelievo rivestito in morbido skay con supporto regolabile*

**GB** *Holder rod for phlebo-bottle and armrest for blood-taking in soft skay with adjustable support*

**F** *Porte-sérum et appui-bras pour prélèvement en tissu doux avec support réglable*

# OTOP/E

POLTRONA PRELIEVO  
BLOOD TAKING CHAIR  
FAUTEUIL PRÉLÈVEMENT

**I** Si tratta di una poltrona specialistica, con schienale e seduta anatomici rivestiti in morbido Peltex, che garantisce al paziente ottima stabilità grazie alla solida struttura e grande ergonomia d'insieme. Lo schienale, reclinabile fino a  $-5^\circ$ , è provvisto di poggiatesta fisso ed anatomico. OTOP/E, che può essere collocata nella posizione di Trendelemburg e nella posizione a lettino, è dotata di due motori ed è movimentata elettricamente tramite appositi attuatori e relativo joystick. I suoi braccioli sono amovibili ed orientabili singolarmente.

La poltrona, in grado di raggiungere una rotazione di  $180^\circ$  con meccanismo di bloccaggio della rotazione, opera un'escursione di 42 cm partendo dalla posizione di riposo a 46 cm dal suolo. Si presenta in una solida struttura e basamento in metallo verniciato a polveri epossidiche.

E' importante notare l'innovativo gambale unico imbottito, studiato per garantire massimo comfort al paziente.

**GB** It is a specialist chair, with anatomical backrest and seat, that gives great steadiness thanks to its solid structure and its uniform ergonomics.

The backrest, that can be reclined till  $-5^\circ$ , is provided with anatomical fixed head-rest.

OTOP/E, that can easily reach both Trendelemburg and bed position, is equipped with two motors electrically moved through actuators and joystick.

Its independent armrests are singularly removable and orientable.

This chair, able to get a rotation of  $180^\circ$  with rotation blocking system, operates a lifting movement of 42 cm from its initial position at 46 cm from the floor.

It is characterized by a steady structure and base painted in epossidic powders.

Please, note the innovative padded single leg-rest conceived to guarantee maximum comfort to the patient.

**F** C'est un fauteuil pour spécialiste avec dossier et assise anatomiques couverts en pratique Peltex, qui donne au patient une stabilité exceptionnelle grâce à sa solide structure et son ergonomie uniforme. Le dossier, inclinable jusqu'à  $-5^\circ$ , est fourni de repose-tête fixe anatomique.

OTOP/E, qui peut facilement rejoindre soit la position de Trendelemburg soit la position à lit étendu, est pourvu de deux moteurs mouvementés électriquement par vérins et relatif joystick. Ses repose-bras rembourrés sont singulièrement amovibles et orientables. Le fauteuil, qui peut gagner une rotation de  $180^\circ$  avec système de blocage de la rotation, opère une excursion de 42 cm à partir de la position zéro à 46 cm du sol. Il se présente avec une solide structure et base en métal vernissé aux poudres époxydiques.

C'est important remarquer l'innovateur repose-jambes pièce unique, étudié expressément pour garantir au patient maximum comfort.

# OTO P/E



## OTO P/E



**I** *Asta portaflebo e bracciolo prelievo rivestito in morbido skay con supporto regolabile*

**GB** *Holder rod for phlebo-bottle and armrest for blood-taking in soft skay with adjustable support*

**F** *Porte-sérum et appui-bras pour prélèvement en tissu doux avec support réglable*

## OTO P/E



**I** *Rotazione di 180° e sollevamento seduta fino a Trendelenburg*

**GB** *Rotation of 180° and seat uplift to Trendelenburg position*

**F** *Rotation de 180° et soulèvement de la siège jusqu'à Trendelenburg*



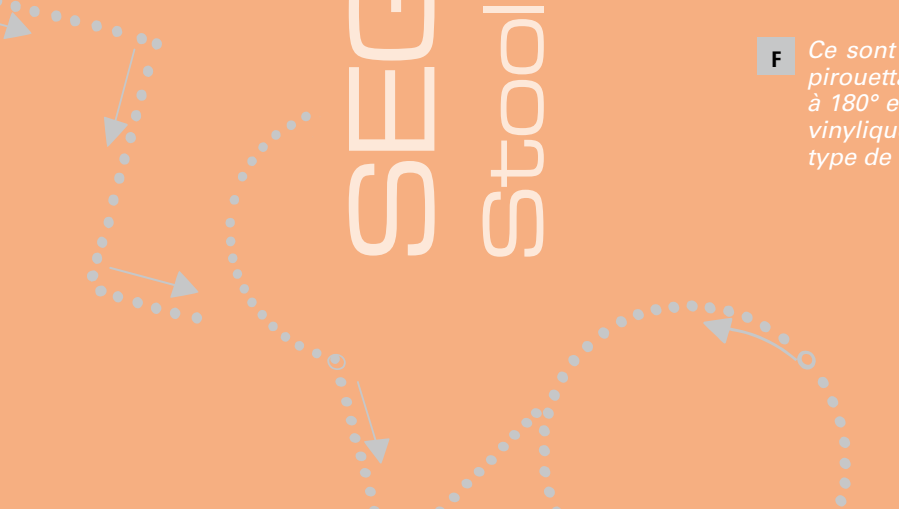

# SEGGIOLINI

## Stools - Tabourets

**I** Sedute per professionisti completamente in acciaio, con basamento pentapiede con ruote gommatae autofrenanti e piroettanti a 360°. Altezza regolabile tramite pompa a gas ed appoggio dorsale registrabile in profondità e girevole a 180°. Le imbottiture sono a densità equilibrata e sono rivestite in Peltex (tessuto polivinilico spalmato ad alta resistenza) in colore a scelta. Tre i modelli: SPD, SPD/A e si differenziano solo dal tipo di basamento.

**GB** They are stools for professional use, completely built in stainless steel, 360° pivoting self breaking castors, rubber-tyred. The height can be comfortably adjusted by means of a gas pump; the back-rest is 180° revolving and depth-adjustable. The seat is balanced density padded and Peltex-lined. There are three models: SPD, SPD/A and they all differ in their specific base shape.

**F** Ce sont tabourets pour spécialistes complètement en acier; la base a 5 points de soutien, avec roues caoutchoutées piroettantes à 360° et autofreinantes. On peut régler l'hauteur à travers la pompe à gas ; le soutien dorsal est tournant à 180° et réglable en profondeur. Les rembourrages ont une densité équitabile et ils sont tapissés en Peltex (tissu polyvinilylique à haute résistance) en couleurs à choix. Les modèles sont trois: SPD - SPD/A et ils diffèrent seulement dans le type de base.

# SEGGIOLINI Stools - Tabourets



SPD



SPD/A



DATI TECNICI · SPECIFICATIONS · FICHE TECHNIQUE		SPD	SPD/A
altezza minima · <i>minimum height</i> · <i>hauteur minimum</i>	mm	530	530
altezza massima · <i>maximum height</i> · <i>hauteur maxi</i>	mm	660	660
peso · <i>weight</i> · <i>poids</i>	kg	13,70	13,70
diametro di base · <i>base diameter</i> · <i>diamètre de base</i>	mm	570	570
anello poggiapiedi diametro · <i>ring foot rest diameter</i> <i>piètement 5 branches avec bague pour pieds diamètre</i>	mm	-	420

## AREA PROGETTAZIONE

DESIGN DEPARTMENT - DEPARTEMENT PROJETS

**I** Euroclinic, avvalendosi di un Ufficio Ricerca & Sviluppo ben strutturato e composto da professionisti dell'ingegneria e del design industriale, realizza non solo progetti tecnici di nuovi prodotti da lanciare sul mercato, ma elabora anche progetti in 3D per l'allestimento di ambulatori completi rispettandone planimetria e particolari esigenze del cliente finale.

Tale servizio di progettazione su misura, completamente gratuito, permette di visualizzare una disposizione ragionata dei prodotti prescelti con proporzioni di spazi/volumi realistiche e perfino di personalizzare a colori le parti di tappezzeria e/o in metallo verniciato.

**GB** Relying on its well organized Research and Development Department composed of professional industrial engineers and designers, Euroclinic carries out not only technical projects of brand new products to launch into the medical market, but it also works out 3D projects for complete doctors' cabinets fully complying to planimetry and to specific customer's requests.

Such project service "at request", completely free of charge, allows to visualize the rational allocation of the chosen products with realistic proportions of space/volume and even to personalize the colours of the parts in skay and/or in painted metal.

**F** Euroclinic, forte de l'appui d'un bureau de RECHERCHE ET DEVELOPPEMENT parfaitement structuré et composé par plusieurs professionnels de l'ingénierie et du design industriel, réalise pas seulement des dessins techniques de nouveaux produits à lancer sur le marché, mais aussi crée des projets trois dimensionnels pour la préparation de cabinets médicaux complets - tout en respectant leur planimétrie et les exigences particulières du client final.

Un tel service de « projet à mesure », complètement gratuit, permet de visualiser une disposition raisonnée des produits choisis, avec des proportions d'espaces/volumes réalistes et détaillés et même de personnaliser en couleur les parties de sellerie et/ou en métal vernissé.

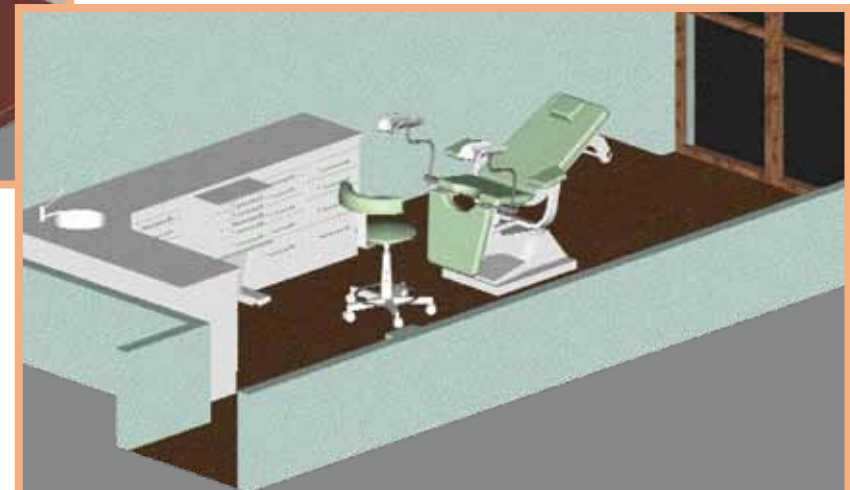
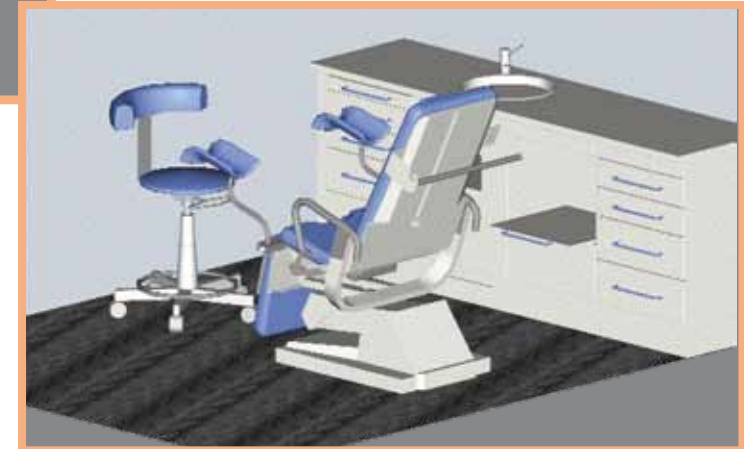

COLORI COLOURS - COULEURS



Novità NEW - NOVEAU



5150  
Metal Silver



5350  
Metal Gold



6450  
Metal Lemon



6650  
Metal Apricot



5850  
Metal Sky Blu



6950  
Metal Blu



7050  
Metal Sea Blu



7250  
Metal Dust Grey



6750  
Metal Red



6050  
Metal Brown

# COLORI COLOURS - COULEURS



01

Bianco Helsinki



02

Grigio Stoccarda



03

Giallo Modena



04

Verde Marbella



05

Verde Dublino



06

Blu New York



07

Azzurro Parigi



08

Blu Chicago



09

Bordeaux Bangkok



10

Arancio Amsterdam



11

Rosso Mosca



12

Grigio Londra



13

Nero Odessa



14

Verde Auckland



15

Verde Honolulu



16

Azzurro Buenos Aires



17

Verde Panama



18

Grigio Milano



19

Giallo Dubai



20

Arancio Praga



21

Verde Sydney



22

Azzurro Miami



23

Blu Copanaghen





24

Verde Vancouver

### SUPREMA U-500

Tensione di alimentazione - Power supply tension - Tension d'alimentation électrique	230 Vac +/-10% ; 50/60 Hz 115Vac +/- 10% ;50/60Hz
Fusibili (L,N) - Fuses (L,N) - Fusibles (L,N)	F1=F2 = 8AT (16AT)
Potenza Max assorbita - Maximum absorbed power - Maximum puissance absorbée	1500VA
Classe secondo IEC 60601-1 - Class according to IEC 60601-1 - Classe selon IEC 60601-1	I B
Cavo alimentazione sezionabile - Selectable power supply cable - câble électrique selectionnable	L=3mt
Motore alzata - Rising motor - Moteur soulèvement	Alimentazione 230Vac Spinta 8000N
Motore Schienale - Backrest motor - Moteur Dossier	Alimentazione 230Vac Spinta 6000N
Motore Trendelenbourg - Trendelenbourg motor - Moteur Trendelenbourg	Alimentazione 230Vac Spinta 8000N
Motore Gambale - Legrest motor - moteur jambière	Alimentazione 24Vdc Spinta 2400N
Capacità di sollevamento - Rising capacity - Capacité soulèvement	200 Kg
Peso della poltrona - Chair weight - Poids fauteuil	130 Kg
Escursione Sollevamento, Inclinazione Trendelenbourg Rising excursion, Trendelenbourg inclination Excursion soulèvement, Inclination Trendelenbourg	350 mm 20° +/- 2°

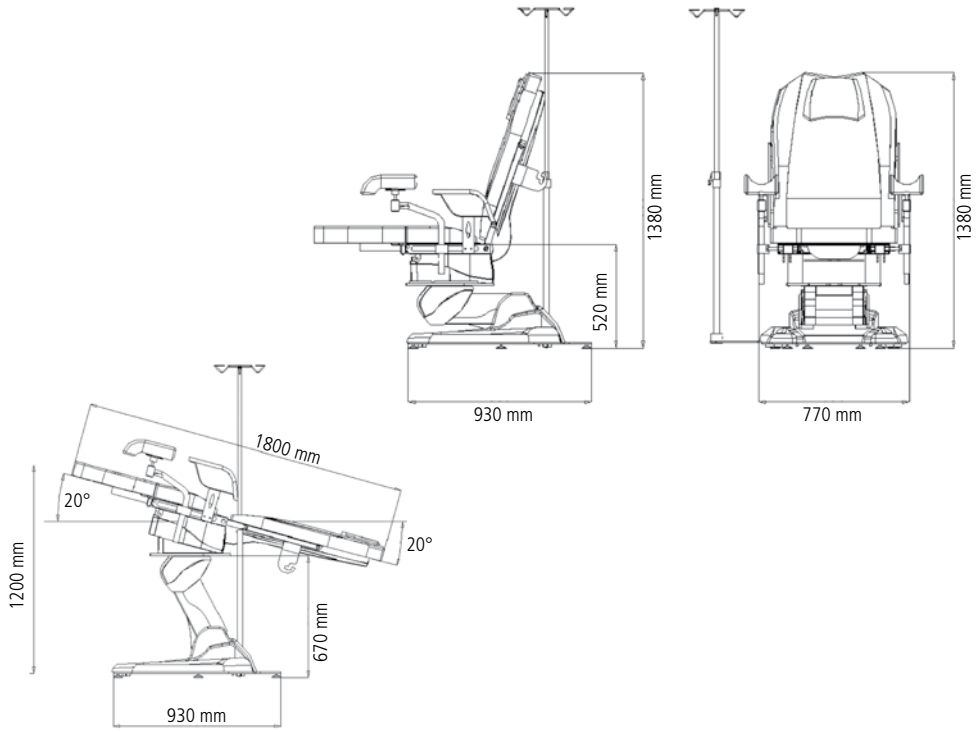
### SUPREMA G-200

Tensione di alimentazione - Power supply tension - Tension d'alimentation électrique	230 Vac +/-10% ; 50/60 Hz 115Vac +/- 10% ;50/60Hz
Fusibili (L,N) - Fuses (L,N) - Fusibles (L,N)	F1=F2 = 8AT (16AT)
Potenza Max assorbita - Maximum absorbed power - Maximum puissance absorbée	1500VA
Classe secondo IEC 60601-1 - Class according to IEC 60601-1 - Classe selon IEC 60601-1	I B
Cavo alimentazione sezionabile - Selectable power supply cable - câble électrique selectionnable	L=3mt
Motore alzata - Rising motor - Moteur soulèvement	Alimentazione 230Vac Spinta 8000N
Motore Schienale - Backrest motor - Moteur Dossier	Alimentazione 230Vac Spinta 6000N
Motore Trendelenbourg - Trendelenbourg motor - Moteur Trendelenbourg	Alimentazione 230Vac Spinta 8000N
Motore Gambale - Legrest motor - moteur jambière	Alimentazione 24Vdc Spinta 2400N
Capacità di sollevamento - Rising capacity - Capacité soulèvement	200 Kg
Peso della poltrona - Chair weight - Poids fauteuil	130 Kg
Escursione Sollevamento, Inclinazione Trendelenbourg Rising excursion, Trendelenbourg inclination Excursion soulèvement, Inclination Trendelenbourg	350 mm 20° +/- 2°



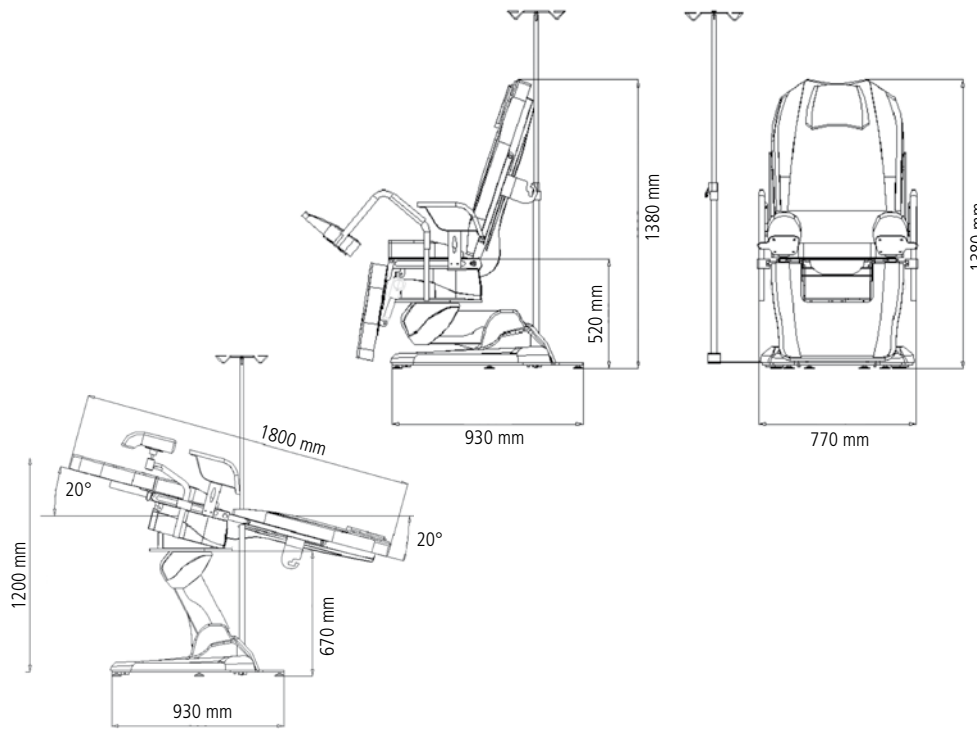

### GYNEX PROFESSIONAL

Tensione di alimentazione - Power supply tension - Tension d'alimentation	230 V - 50 Hz
Tensione ai motori - Motor tension - Tension moteurs	24 V
Spinta motore sollevamento - Lifting motor push - Poussée moteur soulèvement	4000 N
Spinta motori schienale - Backrest motor push - Poussée moteurs dossier	2000 N
Spinta motori gambale - Legrest motor push - Poussée moteurs jambière	2000 N
Capacità sollevamento - Lifting capacity - Capacité soulèvement	180 Kg
Potenza massima - Maximum power - Puissance maximum	90 VA
Protezione da fusibile - Fuse protection - Protection fusibles	1,6 A

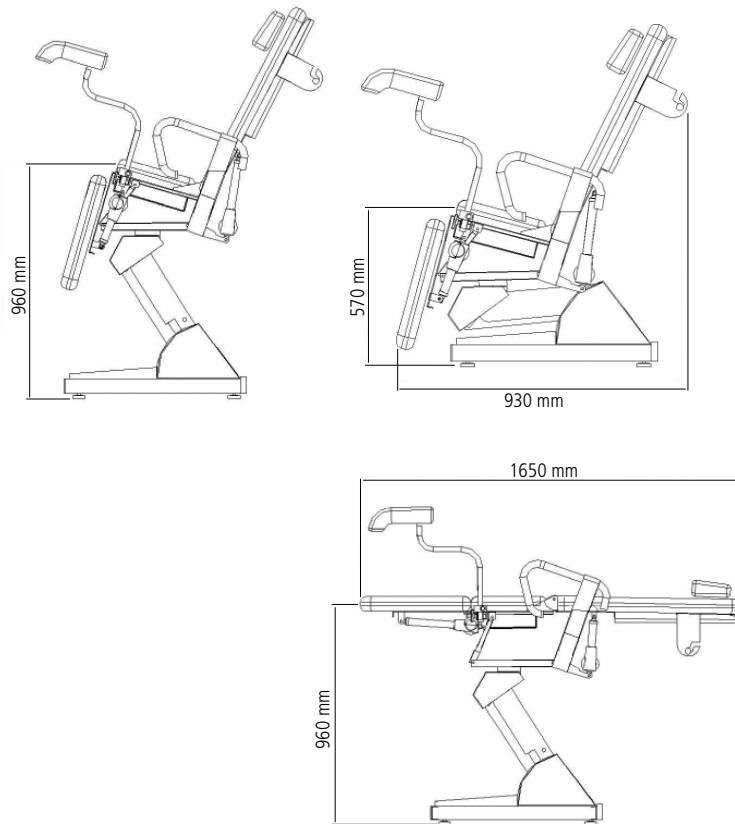

### GYNEX

Tensione di alimentazione - Feeding tension - Tension d'alimentation	230 V - 50 Hz
Tensione ai motori - Motor Power - Tension Moteurs	24 V
Spinta motore sollevamento - Lifting motor push - Pousée moteur soulèvement	4000 N
Spinta schienale - Backrest push - Poussée dossier	800 N
Capacità sollevamento - Lifting capacity - Capacité soulèvement	180 kg
Potenza max - Maximum power - Puissance maximale	90 VA
Protezione da fusibile - Fuse - Fusible	1,6 A

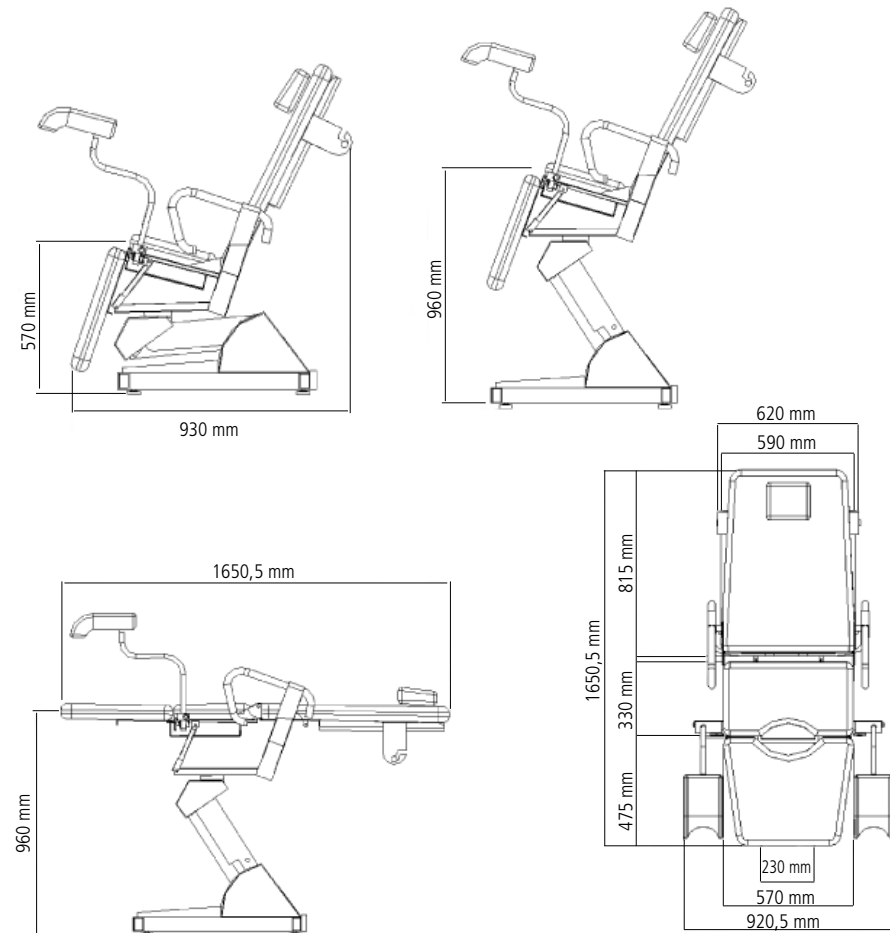

DATI TECNICI TECHNICAL FEATURES - CARACTERISTIQUES TECHNIQUES



MEDICONCEPT

Tensione di alimentazione - Power supply tension - Tension d'alimentation électrique	230 V - 50 Hz
Tensione ai motori - Motor tension - Tension aux moteurs	24 V
Motore Linak bassa tensione - Linak motor low tension - Moteur Linak à basse tension	24 Vdc
Spinta motore sollevamento - Motor Lifting push - Poussée moteur soulèvement	6000 N corsa veloce fast stroke course rapide
Spinta motore schienale - Backrest motor push - Poussée moteur dossier	6000 N
Spinta motore seduta - Seat motor push - Poussée assise dossier	6000 N
Capacità di sollevamento - Lifting capacity - Capacité de soulèvement	200 kg
Potenza assorbita - Absorbed power - Puissance absorbée	120 VA
Peso della poltrona - Chair weight - Poids du fauteuil	120 kg
Lunghezza carter basamento - Base cover length - Longueur couverture base	800 mm
Massima altezza al gambale - Legrest Maximum height - Maximum hauteur jambière	1250 mm

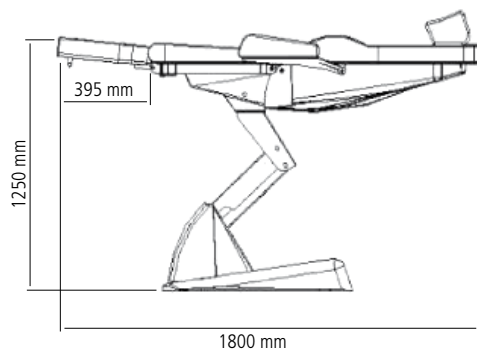
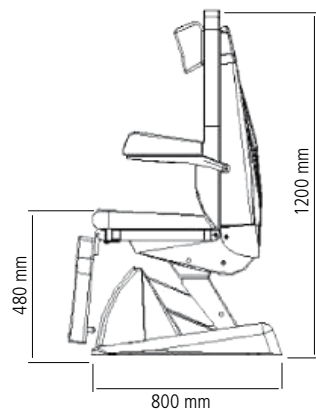

OTO P/E

Tensione di alimentazione - Power supply tension - Tension d'alimentation électrique	230 V - 50 Hz
Tensione ai motori - Motor tension - Tension aux moteurs	24 Vdc
Spinta motore sollevamento - Motor lifting push - Poussée moteur soulèvement	4000 N
Spinta motore schienale - Motor backrest push - Poussée moteur dossier	4000 N
Capacità di sollevamento - Lifting capacity - Capacité de soulèvement	170 Kg
Potenza - Power - Puissance	120 VA
Protezione da fusibile - Fuses protection - Protection fusibles	1,6 A

